

# Q5 SIGNAL VHF/UHF TRANSVERTERS

A Down East Microwave Product Manufactured by Q5 SIGNAL, LLC

**Part Number** L144-28

**SN** \_\_\_\_\_

## Transverter Configuration

Power Out Maximum:	<input type="checkbox"/> 25 W <input type="checkbox"/> 50 W <input type="checkbox"/> 75 W <input type="checkbox"/> 150 W																					
Noise Figure and Gain:	<1.0 dB maximum @ 20 dB conversion gain minimum																					
DC Power Requirement:	11.5 - 15.5 VDC @ <input type="checkbox"/> 7 A Max <input type="checkbox"/> 15 A Max <input type="checkbox"/> 30 A Max																					
IF Option:	<input type="checkbox"/> Common <input type="checkbox"/> Separate TX and RX (Split)																					
RF Option:	<input type="checkbox"/> Common <input type="checkbox"/> Separate TX and RX (Split)																					
IF Drive Level:																						
Keying Option:	<input type="checkbox"/> PTT-L (to ground) <input type="checkbox"/> PTT-H (Positive Voltage)																					
IF Drive Sense:	<input type="checkbox"/> IF Drive Sense																					
Aux Connector Pin #	<table border="1"><thead><tr><th></th><th>Transmit</th><th>Receive</th></tr></thead><tbody><tr><td>1 (Sequencer step 1)</td><td><input type="checkbox"/> High    <input type="checkbox"/> Low    <input type="checkbox"/> Open</td><td><input type="checkbox"/> High    <input type="checkbox"/> Low    <input type="checkbox"/> Open</td></tr><tr><td>2 (Sequencer step 2)</td><td><input type="checkbox"/> High    <input type="checkbox"/> Low    <input type="checkbox"/> Open</td><td><input type="checkbox"/> High    <input type="checkbox"/> Low    <input type="checkbox"/> Open</td></tr><tr><td>3 (Sequencer step 3)</td><td><input type="checkbox"/> High    <input type="checkbox"/> Low    <input type="checkbox"/> Open</td><td><input type="checkbox"/> High    <input type="checkbox"/> Low    <input type="checkbox"/> Open</td></tr><tr><td>4,5</td><td></td><td></td></tr><tr><td>6,7,8</td><td>Ground</td><td>Ground</td></tr><tr><td>9</td><td>PTT</td><td>PTT</td></tr></tbody></table>		Transmit	Receive	1 (Sequencer step 1)	<input type="checkbox"/> High <input type="checkbox"/> Low <input type="checkbox"/> Open	<input type="checkbox"/> High <input type="checkbox"/> Low <input type="checkbox"/> Open	2 (Sequencer step 2)	<input type="checkbox"/> High <input type="checkbox"/> Low <input type="checkbox"/> Open	<input type="checkbox"/> High <input type="checkbox"/> Low <input type="checkbox"/> Open	3 (Sequencer step 3)	<input type="checkbox"/> High <input type="checkbox"/> Low <input type="checkbox"/> Open	<input type="checkbox"/> High <input type="checkbox"/> Low <input type="checkbox"/> Open	4,5			6,7,8	Ground	Ground	9	PTT	PTT
	Transmit	Receive																				
1 (Sequencer step 1)	<input type="checkbox"/> High <input type="checkbox"/> Low <input type="checkbox"/> Open	<input type="checkbox"/> High <input type="checkbox"/> Low <input type="checkbox"/> Open																				
2 (Sequencer step 2)	<input type="checkbox"/> High <input type="checkbox"/> Low <input type="checkbox"/> Open	<input type="checkbox"/> High <input type="checkbox"/> Low <input type="checkbox"/> Open																				
3 (Sequencer step 3)	<input type="checkbox"/> High <input type="checkbox"/> Low <input type="checkbox"/> Open	<input type="checkbox"/> High <input type="checkbox"/> Low <input type="checkbox"/> Open																				
4,5																						
6,7,8	Ground	Ground																				
9	PTT	PTT																				

*Additional Specified Options:*

---

---

---

---

**Configuration Overview:** This transverter is designed to interface and operate with most High Frequency transceivers that are available on the market today. Your assembled unit has been configured to your specifications to interface with your desired transceiver. This configuration may be changed or altered at any time if you desire to utilize a different transceiver or change your system configuration. Let's review your configuration and verify that your interface will be trouble free. Please refer to the front page.

**Part Number Verification:** All transverters contain the operating frequency within the part number. For example, L144-28 means that 144 MHz is converted to 28 MHz. If you ordered a special frequency conversion, it will be listed here. Also, please understand that the conversion is simple math. If you desire to operate on 144.200 MHz with your L144-28, it will require you to tune your transceiver to 28.200 MHz.

**Power Out Maximum:** The part number will identify the transverter as either a high power (HP) or a standard power unit. The output power will be indicated or marked **other** with a hand written level on the line. This level is the **linear** output power level that should not be exceeded if linear operation is expected. The transverter may be capable of producing higher output power. But it is not recommended because of excessive heating that will interfere with its frequency stability while producing excessive distortion products

**Noise Figure and Gain:** The noise figure and gain listed are nominal minimum requirements and most transverters exceed these specifications. In utilizing the latest PHEMPT technology, we have designed the complete receive section of the transverter with extra filtering, diplexing, and gain management in mind. There is also a RXIF gain control that is adjusted by the user to set the "S" meter level on the transceiver. External receive pre-amplification interfacing will be covered later in this document.

**DC Power Requirement:** The DC power requirement is listed and should be used as a guideline. The standard and high power transverters do require different supply currents. Please include some "head room" in your power supply to eliminate voltage drop delivered to the transverter. We recommend a 10-Amp supply for the 25W models, a 20-Amp supply for the 50W and 75W models, and a 35-Amp supply for the 150W models.

**RF Option:** The RF option is either a single port (Common RF) for both TX and RX or there will be two separate ports, (Split RF) one RX and one TX. The HP unit will have an upgraded relay to accommodate the higher power and isolation requirements. This will be an additional cost option. The standard power and HP transverters may be changed from Common to Split if the user desires. This will be covered in the manual. The TR relays are controlled by the Push-to-talk (PTT) circuit.

**IF Option:** The IF options are much like the RF option but in reverse. The transverter may be set up as Split IF (separate TXIF and RXIF in/out lines) or can be configured as a Common IF

**IF Drive Level:** The IF Drive Level is adjustable over a 15-20dB range using the TXIF gain control. Proper adjustment of this level will allow your transverter to operate at its maximum linear output power. The overall drive level range is determined by different sets of attenuators and gain stage levels as required.

**Keying Option:** The keying options are either PTT-L or PTT-H. PTT-L requires a connection to Ground to transmit. This is the most common keying option. PTT-H requires a voltage between 1.7 and 17VDC to transmit. This option can also be placed on the IF coax if desired.

**IF Drive Sense:** This option will be installed with any Common IF drive level above 200 mW. This is a protection circuit that will prevent excessive IF drive levels from damaging the RXIF circuitry and the Mixer in case the PTT circuit fails between the transverter and the transceiver.

The IF drive sense circuit should not be used to key the transverter because it will produce long delays between transmit and receive or chop off the beginning of a transmission.

**Aux Connector Pin #:** The AUX connector is just that. All other I/O's of the transverter are found in this connector. All transverters will have the sequencer pre-wired and will be indicated how it is configured. There are extra pins in the connector and may be specified by the user for various IN/OUT configurations. They will be indicated as such.

**Customer Specified Options:** All other customer specified options will be listed and identified. If for the reason of installing, other options were eliminated, it will be specified and detailed with any special instructions required for correct operation.

## Installation

**Theory of Operation:** The basic principle of a VHF/UHF transverter is to convert a chosen band of operation to the 28 MHz. band of a HF transceiver. Following the recommendations of the HF transceiver's operation manual for transverter use is the most important aspect of correct transverter operation. If configured correctly, the transverter will convert both transmit and receive signals to a new band of operation and seem "invisible" to your HF transceiver's operation.

**Interfacing and Operation:** The interfacing starts with a complete understanding of your HF transceiver and manual. The manual should cover the setup for transverter operation and the connections to be made to the HF transceiver. Some transceivers are simple and some are complex. Some transceivers may have more than one correct way of interfacing. Hopefully, you have decided on how this transverter is to be interfaced at the time of order so we were able to configure the transverter to fit your requirements. If you find that this transverter is not configured correctly, refer to the **Option Setup** section of this manual concerning changing of configuration or contact us directly. All configurations are user changeable and detailed instructions are included.

Start with good quality 50 ohm cables for the IF (28 MHz.) and REF (10 MHz.) connections. These connections are low level (25 watts or less) and are BNC connectors on the transverter. We find that simple RG-58 type BNC cables work fine with or without adapters to your HF transceiver. All transverters will require a PTT Line to enable the transmit mode of the transverter. The PTT input to the transverter is a RCA connector. This cable does not need to be shielded, but extra protection in a QRO station is a good idea! Many transceivers have RCA connectors for PTT outputs. But be sure to have whatever cable that is required ready to go. The DC power cable is supplied with the transverter and needs to be prepped and fuse-protected on the power supply end. The AUX connector will contain all sequencer connections and any other special customer requirements. The matching connector to the AUX connector is supplied and should be wired before interfacing unless further testing of your system is required.

**Connect your transceiver to the transverter:** Interfacing the transverter to the transceiver is easy. After reviewing the front-page configuration and verifying that it is configured correctly for your purpose, begin cabling. **An Important note:** It is recommended that during the initial setup of the transverter, that it is not connected to your complete system with a HPA or mast mount LNA. All aspects of the transverter's performance should be tested before a complete installation is made. Drive levels need to be established and proper switching needs to be verified before complete integration.

1. Connect the DC POWER to the transverter with the supplied cable. 13.8 volts is optimum but the transverter will operate from 11 to 15 volts. Verify the DC power consumption of the transverter and use a power supply with some headroom. Cycle the power switch on the transverter and verify the Green light. Leave the transverter powered off.
2. Connect an optional external 10MHz Reference to the 10MHz REF connector.
3. Connect the IF cable(s). The transverter may have a common IF port or two separate ports, TXIF and RXIF, for the IF connections. The connector labeled "IF" is either the common port or the RXIF port depending on your requested configuration. Verify on the first page. The IF cable is either connected to a transverter port connector or the main Antenna connection of your transceiver. Refer to your manual.
4. Connect the "Push-to-Talk" line out of your transceiver to the transverter. It is a RCA connector labeled PTT on the transverter. Refer to the configuration sheet for the type of keying required.
5. If separate TX and RX ports were ordered, the internal transfer relay option has not been assembled. The separate ports are labeled TX and ANT/RX. If you have requested a common RF connection, the "ANT/RX" port has both TX and RX functions. Connect your antenna system or dummy load with a power meter to the appropriate RF connector on the transverter.
6. On the bottom of the transverter, verify the TXIF and RXIF gain controls in the transverter. Turn the RXIF control fully clockwise and the TXIF control counter-clockwise. This is maximum attenuation on Transmit and minimum attenuation on Receive.
7. Power your transceiver "ON". If your transceiver cycles during power up, it may key the transverter. This is indicated by the Red "XMIT" light and the sound of relays cycling. Verify that the HF transceiver is in "receive" and that the red XMIT light is off on the transverter. If not, shut off your HF transceiver and check the PTT connection with the IF cables disconnected from the transverter. If both transceiver and transverter are in their receive modes, tune the transceiver to a frequency between 28.100 and 28.250 Mhz. Unless you ordered a "non-standard frequency" transverter and then depending on the conversion frequency, select an IF frequency in the middle of you operation range.
8. Observe the noise level in the transceiver on the "S" meter and by ear. If it is too high, adjust the RXIF gain control in the transverter counter-clockwise until a slight noise increase is heard in the transceiver or just a slight movement in the "S" meter is detected. Power the transverter on and off to verify the change. The RXIF gain may be increased beyond this point, but it will start to degrade the dynamic range of your transceiver. It is all user preference. If you plan to use an external or mast mount LNA, this level will need to be re-adjusted. Find a signal on the band or use a signal generator to determine correct frequency, or minimum signal level.

9. It is now recommended to test the transverter's transmit section in the CW mode because most transceivers have carrier level or power level controls in this mode only. Do not use full or semi break-in if possible. Do not use FM, SSB or AM because it may not be possible to obtain maximum output power with a transceiver in these modes. Set the carrier/output power control to minimum or "0" output power (if you can). Place the transceiver into transmit. If the PTT circuit is connected correctly, the red "XMIT" light on the transverter will switch on. While observing the built in relative power meter or an inline RF power meter, slowly increase the carrier control (with key down) or increase the power output control to the maximum desirable IF drive level obtainable by your transceiver (maximum of 25 watts!) If this level is not what is indicated on the front page of this document, do not exceed that level. If you find that the transverter is not set-up for your transceiver's range, go to the **Option Setup** section and re-configure the transverter before further testing.

If the transverter is configured correctly for your transceiver, minimal power may be detected on the power meter. With the transceiver's drive level at maximum specified for the transverter, slowly adjust the TXIF control in the transverter in a clockwise direction while observing the power meter. Set it to any desired level between 0 and the maximum specified output power. The relative power meter is set to show 9 bars lit for the specified maximum linear output power. This may vary with a bad VSWR but will be true into a 50 ohm dummy load. Switch the transceiver to USB and make a transmission. The power output and current drain should correlate to your speech pattern.

10. You may re-adjust both RXIF and TXIF again if desired. The receive amplifier section and internal reference frequency should not need to be adjusted but you may if you wish. Do not adjust any of the helical filters unless you have access to a spectrum analyzer at a minimum.
11. The AUX connector mate may be now wired for your installation. If you require something other than what is indicated on the front page, please see the **Option Setup** section for further details. Also read further about interfacing and testing a mast mounted LNA in that section.

Basically, the transverter is ready to use and may be integrated into your system. If your system requires the use of the sequencer or you desire to implement it, please refer to the **Option Setup** section of this manual.

**General Operation:** General operation of the transverter, if everything is adjusted correctly, should be transparent to the transceiver and the user. Except for the frequency read out, (if your transceiver doesn't allow its display to be adjusted for transverter operation) it will be like operating on 10 Meters. All of the functions of the transceiver (filtering, DSP, split band operation, dual VFO) will be transposed to the frequency band of the transverter.

Some cautions should be taken when operating CW or VOX. Operating the transverter in a "Full Break-in" mode is not recommended. Because of the mechanical relays in the transverter, there will be too much delay to operate "Full Break-in" effectively. AND—the relays would be abused if "Full break-in" is enabled. It is best to operate in "semi break-in" and adjust the delay of the PTT on your transceiver to match your comfortable CW operating speed in a way that the delay will hold the PTT until your transmission is complete. Since all transverters will be delivered with the sequencer enabled, this delay will need to be longer to allow all components within the system (Power amplifier, LNA, relays,) to complete their transition if utilized. If the stock transceiver is to be used alone, the transceiver PTT signal may be connected directly to the transverter's PTT input if the sequencer is bypassed. This will shorten up the delay but will not allow "full break-in" without relay chatter. See the **Sequencer Operation** in the **Option Setup** section of this document.

The "LOCK" LED will be lit when the Frequency Synthesizer is locked to an optional external 10MHz Reference. This level should be between 0dBm to +13dBm. At levels below 0dBm, the synthesizer automatically switches to its on-board reference. And the "LOCK" LED will be off.

## **Option Setup:**

**Common or Split IF Option:** The IF configuration may be changed at any time according to the type of transceiver you are utilizing. The component designators are silk screened on the printed circuit board. K2 is the common IF relay. To split the IF lines into separate RXIF and TXIF, remove the IF coax from its position on the board (junction of K2 and C45) and re-attach the center conductor between C38 and K2. The shield may be now soldered where it was on the ground pad marked COM. The TXIF cable can be prepped and soldered to the pad between K2 and C39. The shield can be soldered to the ground pad labeled TXIF. Install a BNC connector in the rear panel (TXIF) and attach the TXIF coax. Reverse the procedure if you want to change to (or back to) Common IF.

**TXIF Drive Level Range:** The TXIF drive level range can be changed at anytime to conform to your transceiver type. Basically, there are three configurations. For high IF drive levels, (250 mW-25 watts) the 50 Ohm load will be installed with a low value capacitor in the C40 position (10 pF or less for 25 watts). Mid level drives between 1mW and 250 mW will not have the load installed and will have a 1000 pF capacitor installed for C40. For the low drive levels (-20dBm to 0dBm or 1mW) U6 will be installed. If you desire to change the drive level for whatever reason, just duplicate the info above. To install U6, remove the bypass jumper before installing. For -10 to -6dBm inputs, use a MAR-3 for U6. For -20dBm, use a MAR-6. Other MMIC's may be used but the bias resistor R17 may need to be changed. Adjust R15 to obtain the desired level in all cases.

**IMPORTANT NOTE:** Do not assume that low transverter output power is due to inadequate IF drive. Please consult Q5 SIGNAL if you have problems obtaining full output power with your specified drive level.

**Common or Split RF connections:** K1 is the Common RF relay. It may be removed and two separate type "N" or UHF connectors may be installed in the rear panel with coax to the L1 pad for RX and the C30 pad for TX. If you have separate ports and wish to make them common, you can order and install relay K1. Or Q5 SIGNAL can do it for you for a minimum charge

**Sequencer:** The sequencer connections are indicated on the front page and wired to the AUX connector. The reasoning is:

- Step 1 +12VDC on RX for a preamp @ 500 mA maximum
- Step 2 +12VDC on TX for a TR relay (around the preamp) @ 500 mA maximum
- Step 3 Ground on TX to key a power amplifier. Sinks 100 mA maximum
- Step 4 The transverter is keyed last.

Other sequencer configurations are possible including the ability to switch higher voltages. Please contact Q5 SIGNAL for assistance.

For mast mount LNA operation with the basic transverter or with an external high power amplifier, all tests should be done without RF applied. Verify that the switching is completed in your desired sequence and gradually add in external components as verified.

The transverter's sequencer may be bypassed to eliminate switching time delays but is only recommended if the transverter is to be used without any other system components such as LNAs or power amplifiers. This is accomplished by removing the solder bridge labeled "SEQ ENA".

**Relative Power Meter:** The bar graph display is a relative power meter and is driven by the directional coupler and RF detector circuit found in the Low pass filter section of the board (R7,R8,D1,C31). RF is detected and converted to a DC voltage which is routed to the Bar graph display on the front panel. If you find that you operate the transverter at any other level than what we have calibrated it, you may change it by adjusting VR1 on the display board.

**Other Adjustable Circuits:** The Reference Oscillator frequency may be adjusted through a small hole in the TCXO located on the synthesizer board. Its frequency may be monitored at the junction between C34 and M1. Adjust as desired! But be sure the transverter has been “ON” for at least 15 min before measuring frequency. Frequency will shift over time so adjustment is expected.

All filters are aligned by the manufacture for input/output match and pass band ripple. Adjustments are not recommended or required. It's rare to have a failure of a passive component unless excessive “tweaking” has occurred.

### DEM 144-28 COMPONENT LIST

Capacitor (C) values are in pF and are case size 1206

“E” = Leaded Electrolytic “T” = Chip Tantalum

C1 18	C19 1000	C37 1000	C55 0.1uF
C2 NA	C20 NA	C38 1000	C56 4.7uF T
C3 1000	C21 100uF E	C39 1000	C57 1000
C4 22	C22 0.1uF	C40 1000	C58 1000
C5 22	C23 100	C41 1000	C59 10uF T
C6 1000	C24 100uF E	C42 0.1uF	C60 0.1uF
C7 1000	C25 0.1uF	C43 100	C61 1000
C8 0.1uF	C26 100	C44 1000	C62 1000
C9 1000	C27 27	C45 10	C63 1000
C10 1000	C28 33	C46 1000	C64 NA
C11 0.1uF	C29 27	C47 1000	C65 NA
C12 1000	C30 1000	C48 1000	C66 NA
C13 1000	C31 1000	C49 0.1uF	C67 NA
C14 1000	C32 1000	C50 1000	C68 NA
C15 0.1uF	C33 100	C51 33	C69 NA
C16 1000	C34 100	C52 39	C70 NA
C17 0.1uF	C35 NA	C53 33	C71 NA
C18 1000	C36 NA	C54 1000	

Inductor (L) values are in nH and are case size 1008 unless otherwise specified.

L1 1uH	L8 3T #18 3/16" ID	L15 1uH
L2 82	L9 5T #18 3/16" ID	L16 NA
L3 330	L10 5T #18 3/16" ID	L17 56
L4 56	L11 3T #18 3/16" ID	L18 120
L5 56	L12 330	L19 120
L6 1uH	L13 0	L20 56
L7 1uH	L14 330	L21 NA

Resistor (R) values are in Ohms and are case size 1206 unless otherwise specified

R1 51	R11 1K POT	R21 150	R31 1K	R41 NA
R2 330	R12 220	R22 220	R32 1K	R42 NA
R3 100 1W Axial	R13 51 30W	R23 1K	R33 1K	R43 NA
R4 51	R14 220	R24 1K	R34 100K	R44 NA
R5 470	R15 1K POT	R25 1K	R35 1K	R45 NA
R6 NA	R16 220	R26 1K	R36 10K	R46 NA
R7 51	R17 330	R27 1K	R37 10K	
R8 100	R18 1K	R28 470	R38 10K	
R9 51	R19 100K	R29 470	R39 100 1W Axial	
R10 220	R20 330	R30 1K	R40 NA	

### Solid State, Relays, and Filters

D1 HSMS2800	F3 144M-3	Q10 MMBT4403
D2 MPN3404	K1 G5Y	Q11 MMBT4403
D3 MPN3404	K2 G5Y	Q12 MMBT4403
D4 1N4148	M1 SYM18H	Q13 NA
D5 1N4148	Q1 MJD31	U1 TQP3M9037
D6 BAS70-04	Q2 MMBT4401	U2 PHA-1
D7 NA	Q3 MMBT4401	U3 MAR-3
D8 BAT54S	Q4 MMBT4401	U4 MAV-11 / GVA-60
D9 BAT54S	Q5 MMBT4401	U5 RA30H1317M
D10 BAT54S	Q6 MMBT4401	U6 MAR-6
D11 BAT54S	Q7 MJD32	U7 GVA-60
F1 144M-2	Q8 MJD32	U8 LM340AT-5.0
F2 144M-2	Q9 NA	U9 PIC18F13K22



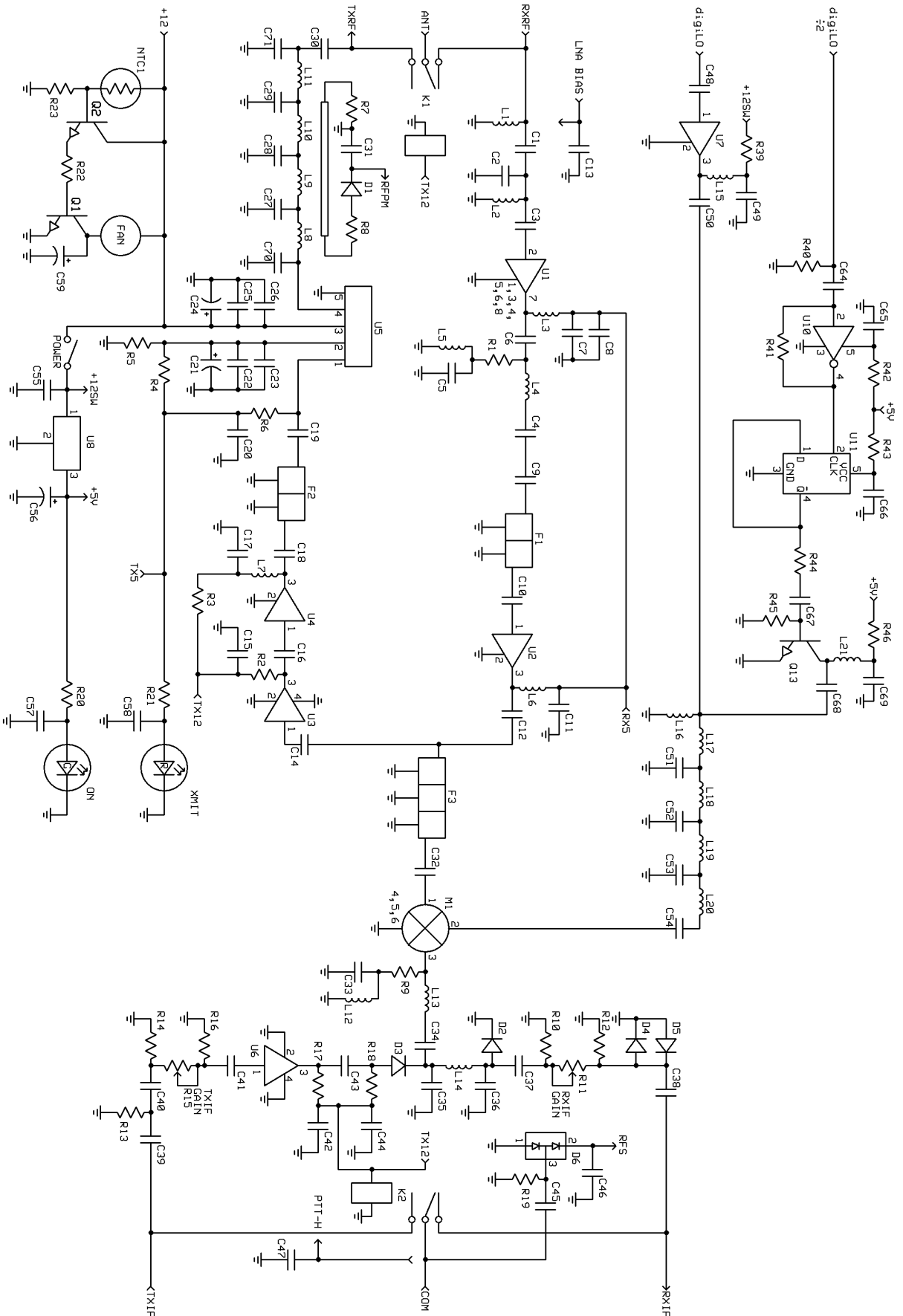

<b>Q5 YHF/UHF TRANSVERTER</b>		
Q5 SIGNAL, LLC	RF MAIN	7-1-2018
C. ABERCROMBIE		V1.0

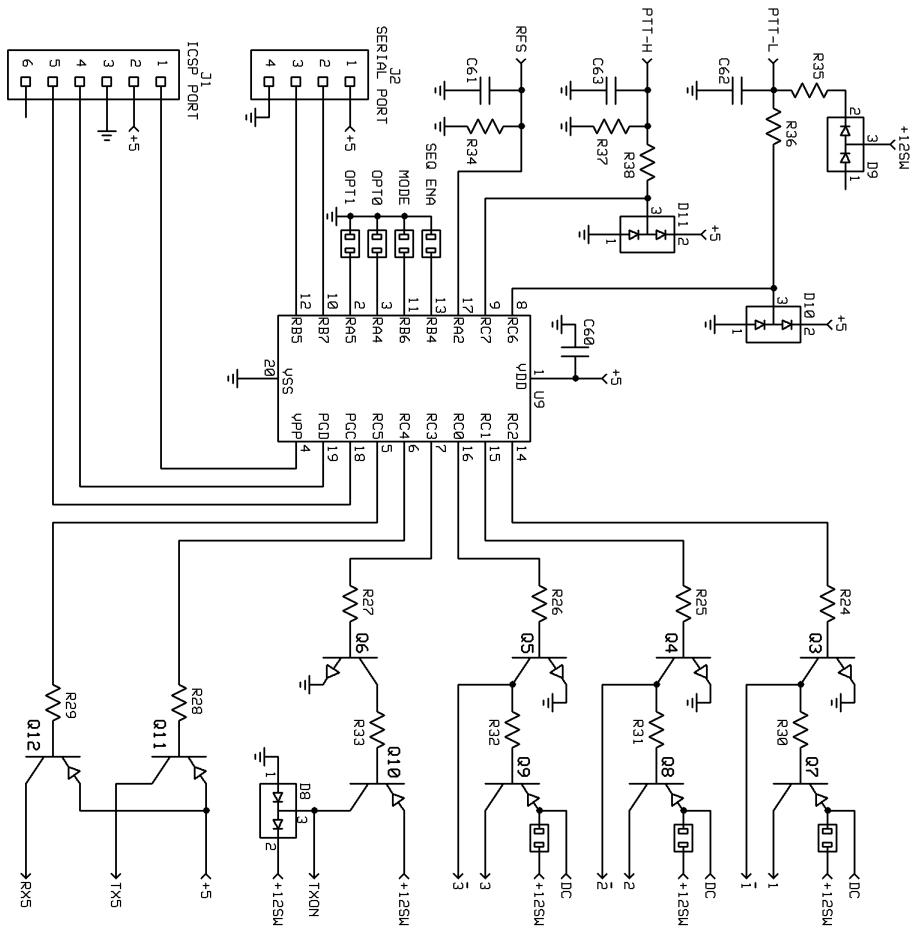

<b>Q5 UHF/UHF TRANSVERTER</b>		
Q5 SIGNAL, LLC	SEQUENCER	7-1-2018
C. ABERCROMBIE		V1.0

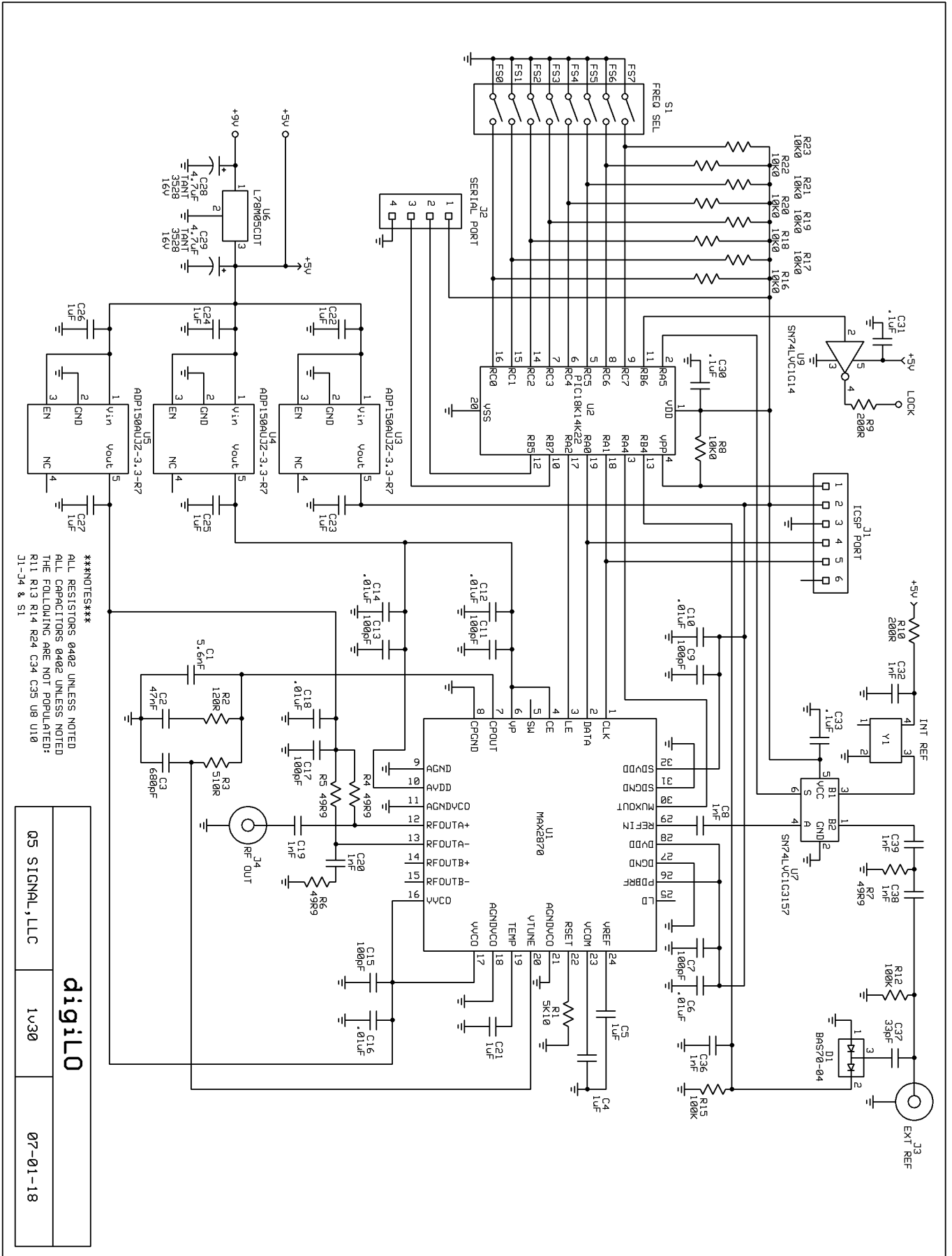

\*\*\*NOTES\*\*\*  
 ALL RESISTORS 0402 UNLESS NOTED  
 ALL CAPACITORS 0402 UNLESS NOTED  
 THE FOLLOWING ARE NOT POPULATED:  
 R11 R13 R14 R24 C34 C35 U8 U10  
 J1-J4 & S1

<b>digiLO</b>		
Q5 SIGNAL, LLC	1v30	07-01-18

# RF Power Meter

BAR1 LTA-1000E	IC1 LM3914
C1 1000pF Cer Disc	R1 2.7K 1/4W
C2 100uF Electrolytic	VR1 10K POT
C3 0.1uF Cer Disc	

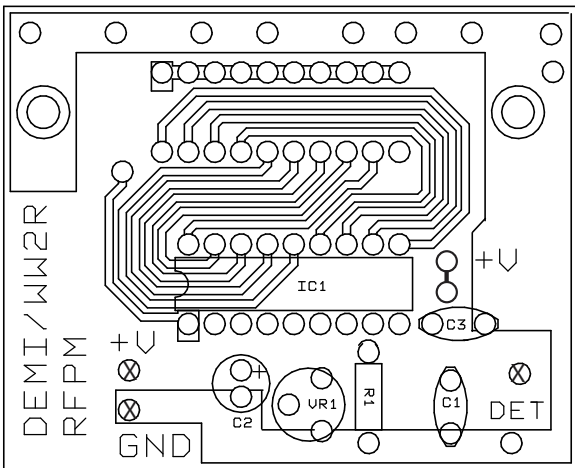
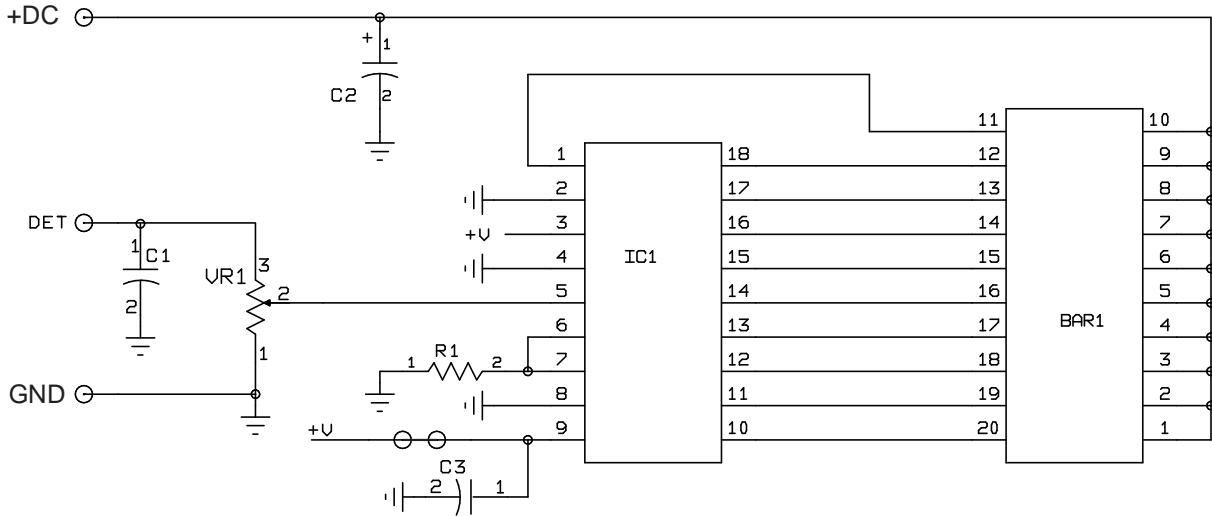

RFPM  
TOP SIDE ASSEMBLY

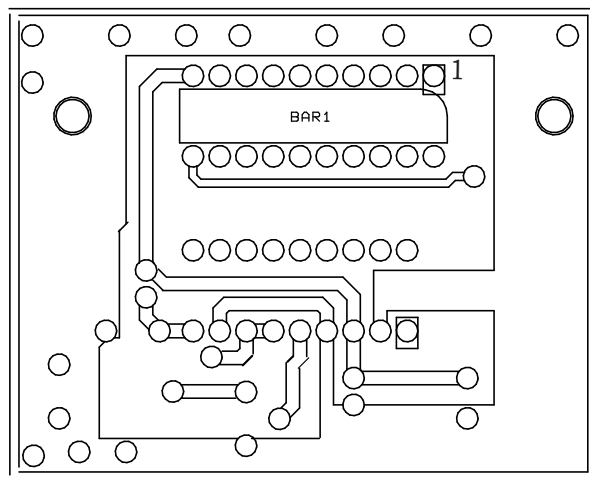

RFPM  
BOTTOM SIDE ASSEMBLY